U4S

4-Port Serial Interface for the Persistor CF-1

Oceanographic Embedded Systems

**1260 NE Seavy Ave.
Corvallis, OR 97330**

e-mail: mark@oes.to

Revision 1.1 October, 2001

Introduction

The U4S is a peripheral interface for the Persistor CF-1 that provides four channels serial I/O with user-selectable baud rates and either polled or interrupt-driven data transfer. The interface card also provides solder pads for an optional RS-485 transceiver and a 10-pin ribbon cable connector for CF-1 console serial I/O.

Setup and Testing

Setting up the U4S requires plugging the CF-1 into the U4S, then plugging the two cards into a recipe card or motherboard to provide power, connecting the CF-1 serial I/O user serial inputs, then running one of the test programs.

CF-1 Serial Port Connections

The console serial I/O connector provides the same RS-232 signals implemented on the Recipe cards from Persistor. It is included since plugging the U4S into a recipe card blocks access to the serial connector on the recipe card. The header is compatible with the IDC-10 to DB9F connector also provided by Persistor. The pin connections of this cable are shown in figure 1.

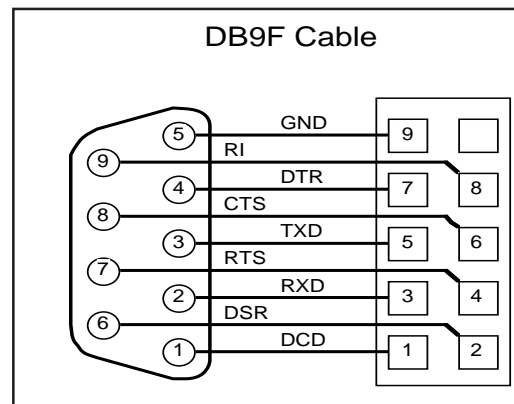

Figure 1. IDC10 to DB9F Cable

Driver Expansion Connections

The U4S has a set of pads for an 8-pin surface-mount RS-485 transceiver. This driver can be used in place of the RS-232 drivers for channel 4. If your application requires the use of an RS-485 driver, please contact OES for further instructions in the use of this option

Power Supply Input

Power is provided to the U4S and the CF-1 through the battery input pin on the 50-pin connector (Pin 13). The U4S uses VReg on Pin 9 to provide power to the UART and RS-232 driver. Your motherboard or recipe card should either connect VREG (pin 13) to VLin (pin 11) or provide a regulated 3.3Volts to pin 13.

When operating at full speed and writing to the compact flash disk, the CF-1 can draw up to 70mA. the U4S adds only about 20mA—depending on the loading of the RS232 ports connected to the card. You should use a current-limited supply set to about 100mA when developing and testing a new system.

The CF-1 linear regulator can accept input voltages to 20Volts without damage. However, if you have a power supply of greater than 11 Volts, it would probably be best to implement a step-down switching converter to provide about 5 volts to the CF-1. A reasonably efficient converter will reduce the current drain on the supply—which can greatly extend the life of a battery. Please contact OES if you have a supply of greater than 12Volts where current drain is important.

Test Software

The diskette provided with the U4S includes several compiled applications that you may use to test your U4S and CF-1. You may also download this software, and other example programs as they are developed, from the OES web page (www.oes.to)

Hardware

The U4S is assembled on two-sided printed circuit board using both surface-mount and through-hole components. The arrangement on the components on the board is shown in figure 2.

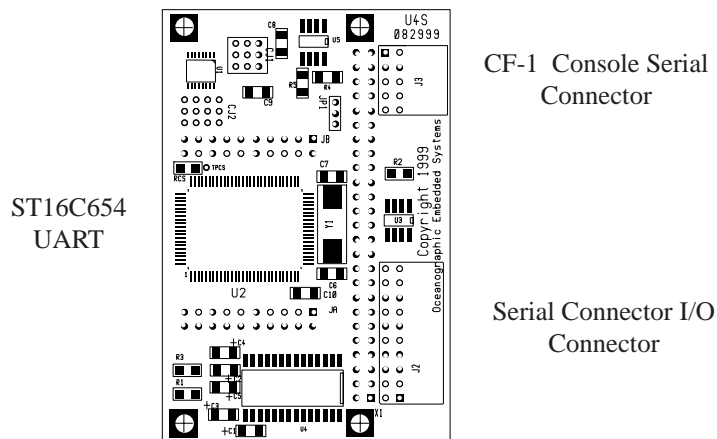

Figure 2. Component layout on U4S PC board.

Exar 16C654D Quad UART

The Exar 16C654 is a quad UART integrated circuit that is designed to interface both to IBM PC and Motorola 68000 buses. The IC provides each channel with a separate baud rate generator, control and configuration registers, and 64-byte First-In-First-Out (FIFO) buffers. These FIFOs greatly reduce the number of interrupts that the processor must handle during high-speed communications sessions.

The 16C654 is powered directly by the +3.3V supply from the CF-1. It normally requires only about 3mA during operation. Since there is no way to shut off power to the UART during operation, you cannot eliminate the power drain of the UART except by putting the CF-1 into the suspend mode—which turns off the +3.3V supply. It is not possible to simply turn off power to the 16C654, since it is directly connected to the address and data busses of the CF-1's microcontroller.

U4S Serial I/O Connections

The U4S provides a 20-pin dual-row right angle header for Serial I/O. All the odd-numbered pins are connected to system ground. The serial I/O signals appear on the even-numbered pins as shown in Figure 3.

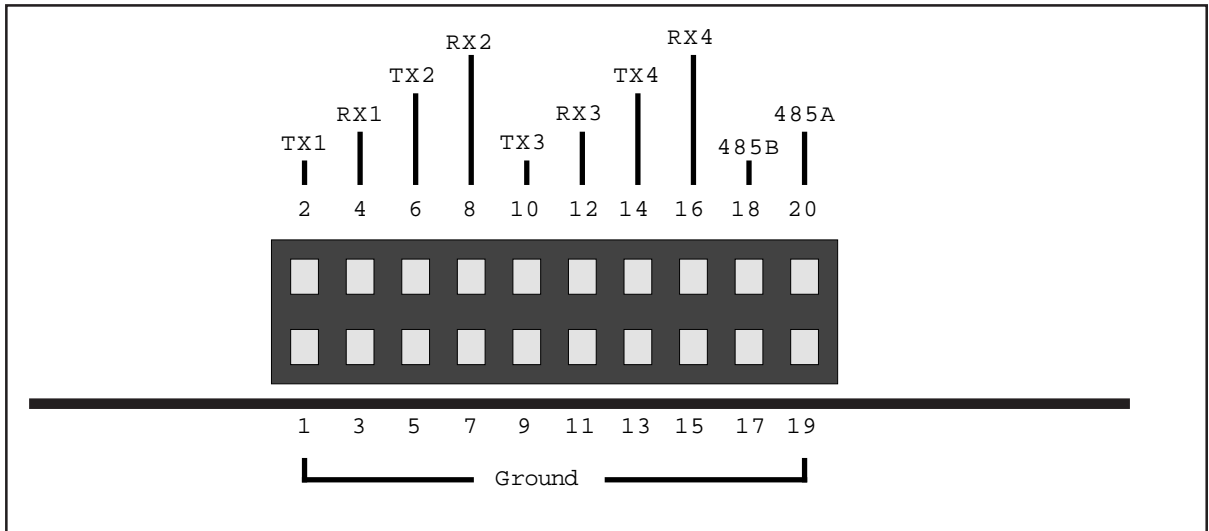

Figure 3. Serial I/O Connector Pin Assignment

Chip-Select Jumpers

The 16C654D UART is connected directly to the address and data busses of the CF-1. In order for it to operate properly, the UART must respond to a unique set of memory addresses. The Sandwich Card specifications allocate a 32-KByte block of memory, divided into 32 1-KByte blocks for all the Sandwich Cards in a system. Two sets of address jumpers are used to select one of these blocks for a particular card. The 1-KByte blocks are generally referred to as address slots. The default slot for a U4S is 5. The layout of the address jumpers for slot 5 is shown in Figure 4. These chip-select jumpers appear in the upper left corner of the board in Figure 2. If a second U4S card is added to your system, you should set CS2 to select block 6.

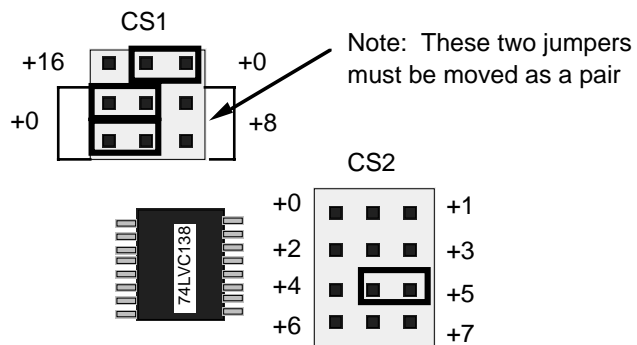

Figure 4. Layout of Chip -Select Jumpers

Sandwich Card Supervisor and Environment Variables

The U4S has an onboard Sandwich Card Supervisor (SCS) chip which can inform the CF-1 of the type and serial number of the U4S card. This supervisor chip communicates with the CF-1 using a serial protocol on two seldom-used pins, IRQ7 and MCLK. The firmware library for the U4S will interrogate the SCS of any attached Sandwich Cards to be sure there is a U4S available before it will attempt to transfer data to and from the UART chip. However, the SCS supervisor cannot easily determine the slot address of the card--which the library routines need for proper operation. For this reason, you should define an environment variable to inform the software which slot is being used by the CF-1. You can do this by typing the following line at the PicoDos prompt:

```
set SCB.5=U4S.3020.1000.100.2
```

This line defines an environment variable named SCB.5 and associates the data string "U4S.3020.1000.100.2" with the name. The name and data are stored in the virtual EEPROM of the CF-1. The "SCB.5" indicates that the variable is associated with a sandwich card in slot 5. (Each SCB variable will have the slot number after the period in the name.)

The data string defines the card as a U4S and indicates the manufacturers' product identifier (3020) and the serial number of the board (1000). It also indicates the minimum Chip Select pulse width (100 nanoseconds) and the interrupt used by the board (2). Periods must be used as separators because more common separators, such as commas or spaces, interfere with the storage routines for environment variables.

The diskette included with the U4S includes a program, FINDU4S.RUN, which will search the memory occupied by the sandwich card slots and attempt to find any U4S cards in the system. If it finds a U4S, it will set the appropriate environment variable. This program reads and writes a data pattern to all the potential memory addresses that might be used by certain registers on the U4S. However, if it reads and writes to an address occupied by another type of peripheral, it may have an adverse affect on that peripheral.

WARNING: The FINDU4S program may adversely affect other peripherals. You should not run this program if other peripherals may be using CS8 or CS10.

Interrupt Selection

When used in interrupt-driven operation, the U4S can interrupt the processor using IRQ2 or IRQ5. The U4S is normally shipped with IRQ2 selected. If you are using IRQ2 for other interrupts in your system, you may select IRQ5 by moving the jumper. The PIC Sandwich Card Supervisor and U4S firmware will determine which interrupt is selected and set up the software to use it properly.

Stacking Multiple Sandwich Cards

The U4S, and other sandwich cards, are designed to be stacked to allow several cards to be included in your system. The cards stack with 0.4 inches between adjacent board. (If you don't have 0.4" spacers, try a 3/8" spacer and a 0.032" washer.)

Software

U4S Library

A library of software routines for the U4S is provided as a binary library compatible with the MetroWerks Codewarrior Pro development system.. The library files (U4S.lib and U4S.h) provide routines to initialize the quad UART and to send and receive data from the serial I/O ports. The serial ports may be operated in either polled mode or in interrupt-driven mode with buffer sizes you select.

Library Functions

The following functions are defined in the U4S library. The header file and library are included on the diskette.

Function Prototype

```
short U4SFindCards(bool verify);
```

Parameters

When *Verify* is true, function will poll the register addresses of potential U4S card slots to verify the presence of the UART hardware.

Return Value

The function returns the number of U4S cards found.

Usage

This function searches the environment variables to see if they indicate a U4S at any valid slot number. If the return value is zero, you have no U4S cards available and should not use any further library functions. If a valid card is found, a record in the `u4Devs` array is filled in, indicating the base address of the U4S slot and the IRQ used by the card.

Function Prototype

```
void U4SInitChannels(void);
```

Usage

This function initializes the registers of the U4S cards found in the call to `U4SFindCards`. (In the first release, only the first card is initialized.)

Function Prototype

```
bool U4SInitInputQueue(short chan, short qsize);
```

Parameters

chan selects which of the UART channels to initialize (1 through 4).

qsize sets the size of the queue to be used with the channel. Reasonable values should be in the range from 128 to 4095. Memory for the data in the input queue is allocated in the system heap with a call to `malloc()`.

Return Value

The boolean result is true if the queue is successfully initialized. It is false if the memory for the queue data could not be allocated.

Usage

This function is used to define queue sizes for an input channel and to set up the channel for interrupt-driven I/O. If you do not call this function, the channel will operate in polled mode. (In the initial release, queues are set up only for the first U4S card.)

Function Prototype

```
bool U4SInitOutputQueue(short chan, short qsize);
```

Parameters

chan selects which of the UART channels to initialize (1 through 4).

qsize sets the size of the queue to be used with the channel. Reasonable values should be in the range from 128 to 4095. Memory for the data in the input queue is allocated in the system heap with a call to `malloc()`.

Return Value

The boolean result is true if the queue is successfully initialized. It is false if the memory for the queue data could not be allocated.

Usage

This function is used to define queue sizes for an input channel and to set up the channel for interrupt-driven I/O. If you do not call this function, the channel will operate in polled mode. (In the initial release, queues are set up only for the first U4S card.)

Function Prototype

```
bool U4SInitPPB(short chan, short qsize, vfptr notify);
```

Parameters

chan selects which of the UART channels to initialize (1 through 4).

qsize sets the size of the ping-pong buffer to be used with the channel. Reasonable values should be in the range from 512 to 4095 bytes. Memory for the buffer is allocated in the system heap with a call to `malloc()`. Ping-pong buffers are used for input only.

Return Value

The boolean result is true if the ping-pong buffer is successfully initialized. It is false if the memory for the buffer could not be allocated.

Usage

This function is used to set up a ping-pong buffer for an input channel and to set up the channel for interrupt-driven I/O. (In the initial release, a PPB can be set up only for the first U4S card.) Ping-Pong buffers are an efficient way to collect data to be written to flash disk. They are much less useful than queues when you need to examine the incoming serial data stream.

Function Prototype

```
void U4SConfigure(short chan, long baud, char parity, char bits, char stop);
```

Parameters

chan selects which of the UART channels to initialize (1 through 4).

baud sets the baud rate. You can select standard baud rates from 300 to 230,400 baud. Both the input and output channels will use the selected baud rate.

parity defines the parity of the characters transmitted and received. Valid settings are :

- 'n' no parity bit used
- 'e' set parity bit so an even number of logic 1s are transmitted
- 'o' set parity bit so an odd number of logic 1s are transmitted
- '0' set parity bit to 0
- '1' set parity bit to 1

bits sets the number of bits in the character. Only values of 5 through 8 are valid. Only values of 7 and 8 are used in normal computer-to-computer applications.

stop sets the number of stop bits. Only values of 1 and 2 are valid.

Usage

This function must be called before the channel is used, to properly define the baud rate and character format.

Function Prototype

```
void U4STxPutChar(short chan, ushort data);
```

Parameters

chan selects which of the UART channels that will transmit the data(1 through 4).

data specifies the character to send. The parameter is of type ushort because the standard libraries use and INT or SHORT—but you will usually be transmitting characters.

Usage

This function is used to transmit data through the UART channel. In polled mode, it will wait inside the routine until the UART transmit register is empty (up to one character time). However, there will be no delay unless the FIFO buffer is full. In interrupt-driven mode, the character will be put into the queue to be transmitted by the interrupt handler.

Function Prototype

```
ushort U4SRxGetChar(short chan);
```

Parameters

chan selects which of the UART channels will receive the data (1 through 4).

Return Value

The return value is the character received (promoted to a ushort).

Usage

In polled mode, the function will wait until a character is received. This could hang your program! In interrupt-driven mode, the routine will return the character 0x00 if there is no received data available. For this reason, you should always call U4RxCharsAvail() to check for received data before you call U4RxGetChar().

Function Prototype

```
ushort U4SRxCharsAvail(short chan);
```

Parameters

chan selects which of the UART channels to check for incoming data(1 through 4).

Return Value

The return value is the number of receive characters available.

Usage

In polled mode, the return value will be one when there is a received character available. Since the 16C654 has a 64-byte receive FIFO, you may have to call `U4RxCharsAvail()` and `U4RxGetChar()` many times to get all the characters received. In interrupt-driven mode, the function returns the number of characters in the receive queue. There may be characters in the UART FIFO which have not yet been added to the input queue.

Function Prototype

```
bool U4STxComplete(short chan);
```

Parameters

chan selects which of the UART channels to check for outgoing data transmission complete.

Return Value

The return value is true when all transmission from the channel is complete

Usage

This function can be used to determine whether all transmission from the serial channel is complete. It checks both the transmitter holding register (and FIFOs if enabled) and the serial data shift register.

Function Prototype

```
void U4SClose(void);
```

Parameters

NONE

Usage

This function disables the interrupts—both at the IRQ pin and in the interrupt-enable registers of the UART. It also frees the memory (if any) allocated for input or output queues or ping-pong buffers.

Function Prototype

```
void U4SFlush(short chan);
```

Parameters

chan selects which of the UART channels will have the buffers flushed

Usage

This function clears both the transmit and receive queues of the channel(if queues are enabled). It also empties the send and receive FIFOs of the UART.

Function Prototype

```
short U4XmitErrorCode(short chan);
```

```
short U4RcvErrorCode(short chan);
```

Parameters

chan selects which of the UART channels will report errors (1 through 4).

Return Value

The return value is an indication of the most recent error.. (more codes to be defined later)

Usage

This function returns a unique code for each error. The code is cleared to 0 when the error code is read. 0 = NoError 1 = tried to put data in full queue 2 = tried to get data from empty queue 4 = illegal channel number.

Function Prototype

```
void U4SClk4x(short chan);
```

```
void U4SClk1x(short chan);
```

Parameters

chan selects which of the UART channels will change its clock divisor.

Usage

This function enables and disables an internal 4x divisor in the baud rate clock. The default is to enable the divisor, which provides the normal baud rates. If you call U4SClk1x, the divisor is disabled and all baud rates are multiplied by 4. You need to call U4SClk1x only if you need baud rates above 115.2KBaud with a U4S.

Function Prototype

```
void U4SBreak(short chan, long ticks);
```

Parameters

chan selects which of the UART channels will send a break.

ticks sets the length of the break in units of 1/65536 second.

Usage

This function is used to set a break state on an output line. The processor will remain in the function for the duration of the break state.

Function Prototype

```
void U4SDTRState(short chan, short state);
```

```
void U4SRTSState(short chan, short state);
```

Parameters

chan selects which of the UART channels will change its clock divisor.

state determines whether the DTR or RTS bit is a one or a zero.

Usage

These functions are used to set and clear the RTS bits of the UART channels. RTS and DTR on channel 2 are used to enable the RS-232 driver chip. The default high state enables the RS-232 driver. RTS on Channel 4 controls the optional RS-485 driver. The default high state enables the RS-485 output and disables the receiver. There are no external connections to these signals, so they cannot be used for serial handshaking. interrupt response of the CF-1 and the 64-byte receive FIFO of the 16C654. Input handshaking generally not required with the CF-1 and U4S due to the fast interrupt response of the CF-1 and the 64-byte receive FIFO of the 16C654.

Sample and Support Programs

The diskette provided with U4S provides source and compiled .RUN code for several sample programs illustrating the use of the U4S. These must be loaded into the CF-1 using the MotoCross loader from Persistor.

U4SFile

This program uses Serial Channel 1 to transmit data at 19200 baud and receives the same data through channels 1 through 4. The input data from each channel is stored in a separate file on the compact flash disk attached to the CF-1. In order to collect data, you must connect jumper wires from the TX output of channel 1 to each of the four RX inputs.

FindU4s

This program scans through the Sandwich Cards attached to a CF-1, looking for U4S cards. When it finds one, it offers to define an environment variable that can be used by other programs to properly initialize the U4S.

Appendix 1. Block Diagram

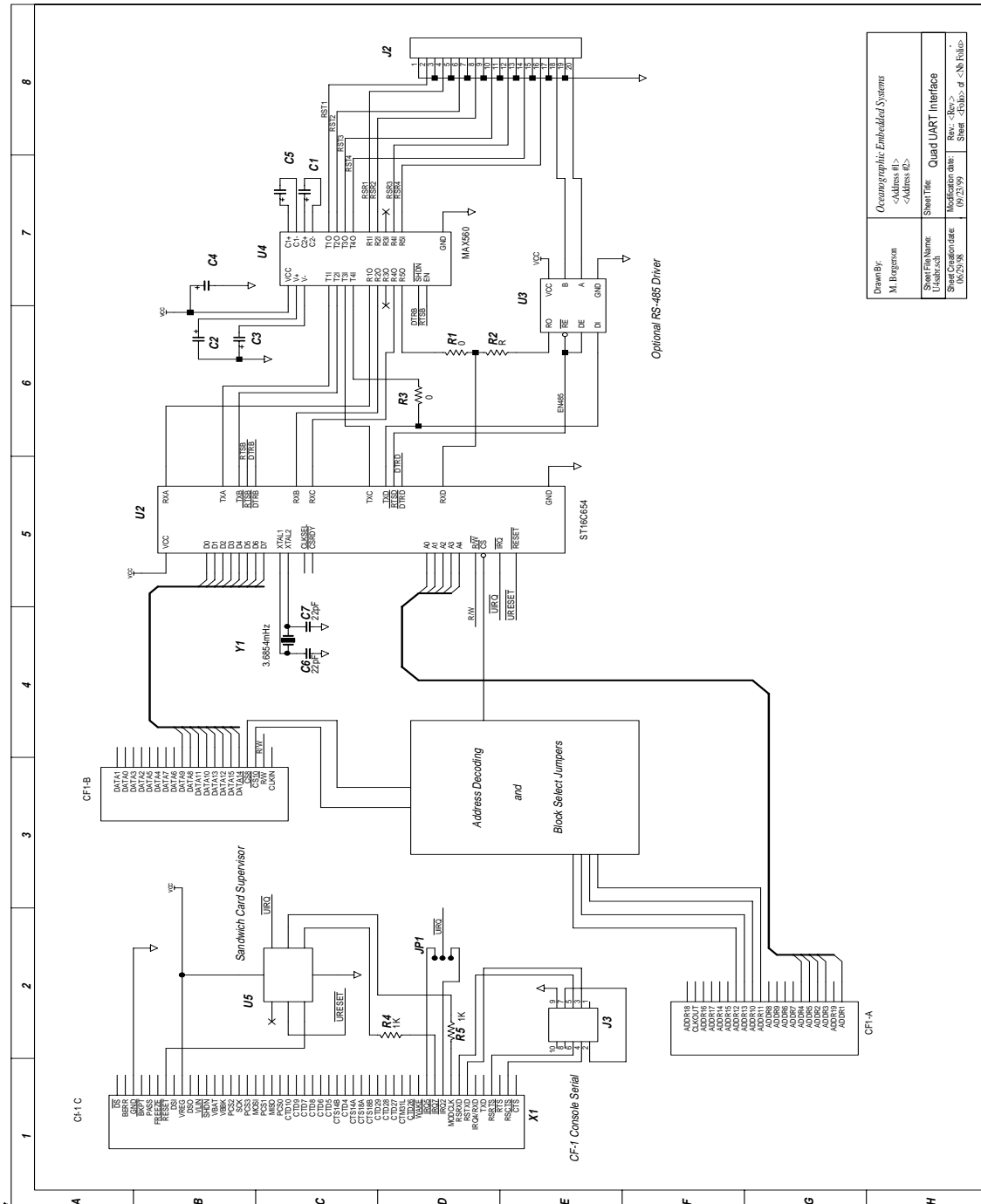

Drawn By:	M. Borgeson	Sheet Name:	U4RS-485
Checked By:		Sheet Title:	Quad UART Interface
Modification date:	09/27/99	Revision:	Rev. <Rev.>
Sheet:	1 of 1	Sheet:	Sheet -<Sheet> of -<Nb Sheets>